

Pressure reducing valve, direct operated

RE 26580/05.11
Replaces: 02.03

1/8

Type DR 10 DP

Size 10
Component series 4X
Maximum operating pressure 210 bar
Maximum flow 80 l/min

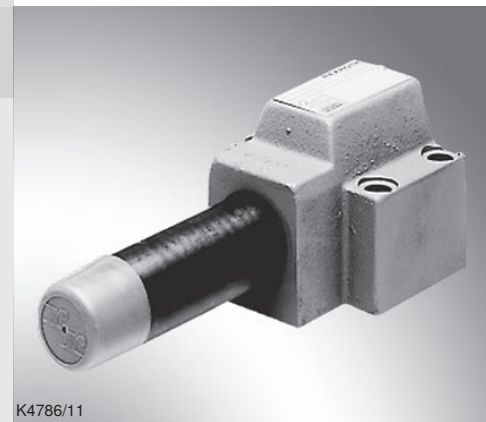

Table of contents

Contents	Page
Features	1
Ordering code	2
Symbols	2
Function, section	3
Technical data	4
Characteristic curves	5
Unit dimensions	6, 7

Features

- For subplate mounting
- Porting pattern according to DIN 24340 Form D and ISO 5781-06-07-0-00
- 4 adjustment types for pressure adjustment, optionally:
 - Rotary knob
 - Setscrew with hexagon and protective cap
 - Lockable rotary knob with scale
 - Rotary knob with scale
- 4 pressure ratings
- With pressure gauge connection
- Check valve, optional
- More information:
 - Subplates

Data sheet 45062

Ordering code

DR 10 DP	-4X/	Y			*
----------	------	---	--	--	---

Pressure reducing valve, direct operated, size 10

Adjustment type

Rotary knob	= 1
Setscrew with hexagon and protective cap	= 2
Lockable rotary knob with scale	= 3 ¹⁾
Rotary knob with scale	= 7
Component series 40 to 49 (40 to 49: Unchanged installation and connection dimensions)	= 4X
Maximum secondary pressure 25 bar	= 25
Maximum secondary pressure 75 bar	= 75
Maximum secondary pressure 150 bar	= 150
Maximum secondary pressure 210 bar	= 210

Further details in the plain text

Seal material

No code = NBR seals
V = FKM seals
 (other seals upon request)
 Attention!
 Observe compatibility of seals with hydraulic fluid used!

No code = With check valve
M = Without check valve

Y = Pilot oil supply internal, leakage oil discharge external

¹⁾ H-key with Material no. **R900008158** is included in the delivery.

Standard types and standard units are contained in the EPS (standard price list).

Symbols

Version "M"
without check valve

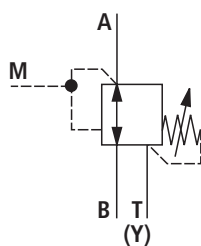

"No code" version
with check valve

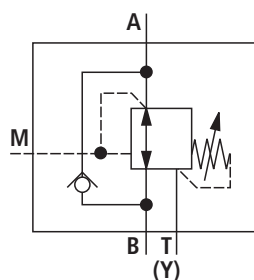

Function, section

The valve type DR 10 DP is a direct operated pressure reducing valve in 3-way design, i.e. with pressure limitation of the secondary circuit.

It is used to reduce a system pressure. The secondary pressure is set via the adjustment type (1).

In the initial position the valve is open. Hydraulic fluid can flow from channel B to channel A without obstructions. Via the pilot line (4), the pressure in channel A is applied to the spool face vis-à-vis the compression spring (3). If the pressure in channel A rises above the value set at the compression spring (3), the control spool (2) moves into the control position and holds the set pressure in channel A constant.

Signal and pilot oil are provided internally, via the control line (4) by channel A.

If the pressure in channel A continues to increase due to external forces at the actuator, it moves the control spool (2) further against the compression spring (3).

Thus, channel A is, via the control edge (5) at the control spool (2), connected with channel T(Y). Hydraulic fluid flows to the tank until the pressure can only increase slightly.

The leakage oil drain from the spring chamber (6) is always realized externally, via channel T (Y).

For the free flow back from channel A to channel B, you can optionally install a check valve (7).

A pressure gauge connection (8) allows for the control of the secondary pressure.

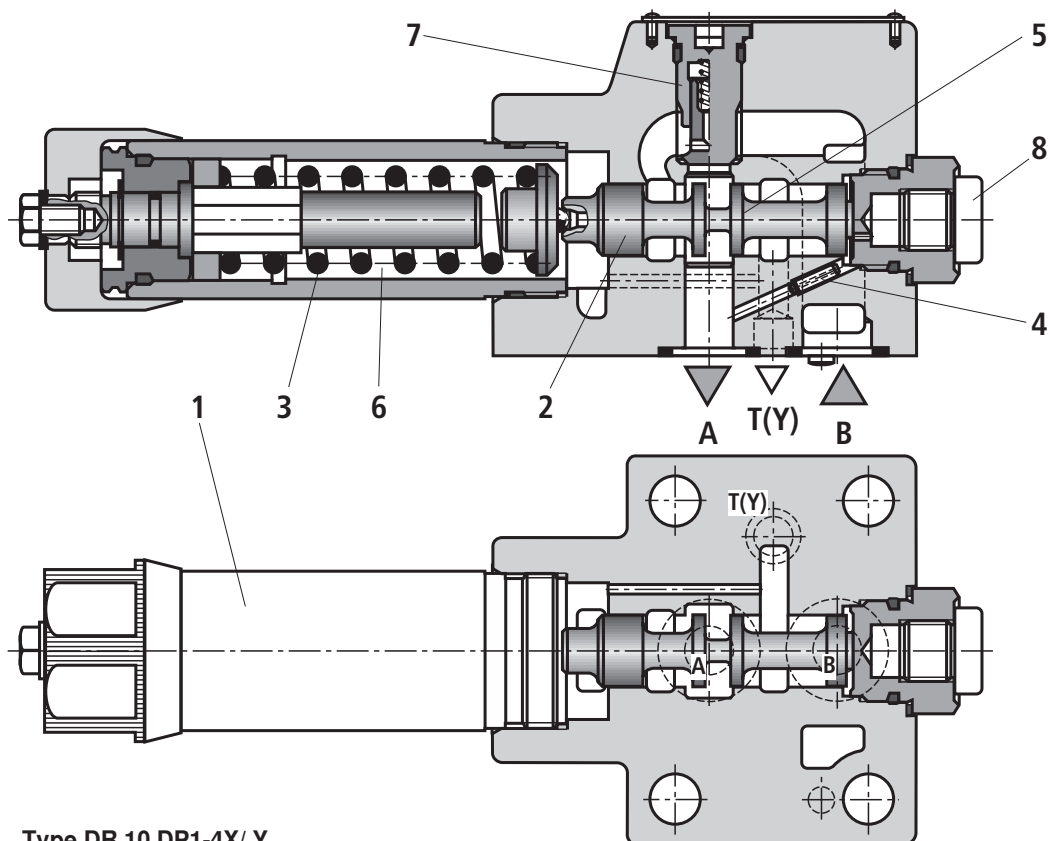

Type DR 10 DP1-4X/Y...

Technical Data (For applications outside these parameters, please consult us!)**general**

Weight	kg	3
Installation position		Any
Ambient temperature range	°C	-30 to +50 (NBR seals) -20 to +50 (FKM seals)

hydraulic

Maximum operating pressure – Port B	bar	315
Maximum secondary pressure – Port A	bar	25; 75; 150; 210
Maximum backpressure – Port T (Y)	bar	160
Maximum flow	l/min	80
Hydraulic fluid		See table below
Hydraulic fluid temperature range	°C	-30 to +80 (NBR seals) -20 to +80 (FKM seals)
Viscosity range	mm ² /s	10 to 800
Maximum permitted degree of contamination of the hydraulic fluid - cleanliness class according to ISO 4406 (c)		Class 20/18/15 ¹⁾

Hydraulic fluid	Classification	Suitable sealing materials	Standards
Mineral oils and related hydrocarbons	HL, HLP, HLPD	NBR, FKM	DIN 51524
Environmentally compatible	– Insoluble in water	HETG HEES	NBR, FKM FKM
	– Soluble in water	HEPG	FKM
Flame-resistant	– Water-free	HFDU, HFDR	FKM
	– Water-containing	HFC (Fuchs Hydrotherm 46M, Petrofer Ultra Safe 620)	NBR

 **Important information on hydraulic fluids!**

- For more information and data on the use of other hydraulic fluids refer to data sheet 90220 or contact us!
- There may be limitations regarding the technical valve data (temperature, pressure range, service life, maintenance intervals, etc.)!

– Flame-resistant – water-containing:

- Maximum operating pressure 210 bar
- Maximum hydraulic fluid temperature 60 °C
- Expected service life as compared to HLP hydraulic oil 30 % to 100 %

Characteristic curves (measured with HLP46, $\vartheta_{oil} = 40 \pm 5 \text{ }^\circ\text{C}$)

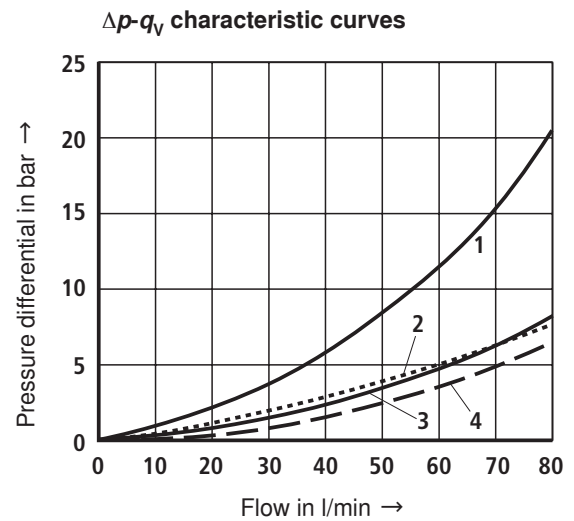
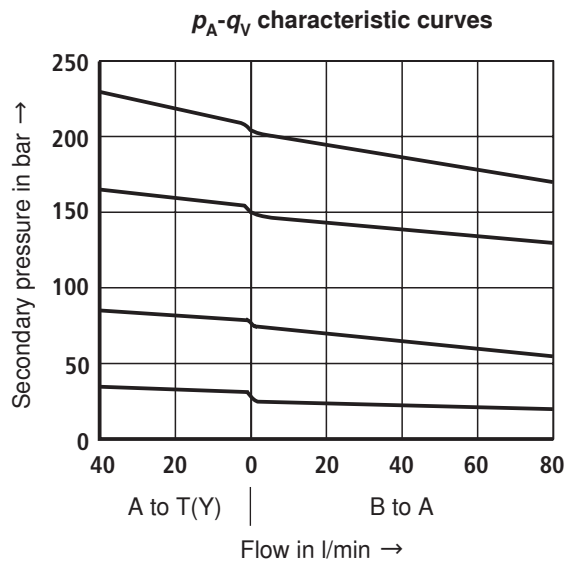

Note!

With lower pressures set, the curve development is maintained according to the pressure rating.

The characteristic curves apply to the pressure at the valve output $p = 0$ bar across the entire flow range.

- 1 A to T (Y) (minimum pressure differential)
- 2 B to A (minimum pressure differential)
- 3 Δp only via check valve
- 4 Δp via check valve and completely opened control cross-section

Unit dimensions (dimensions in mm)

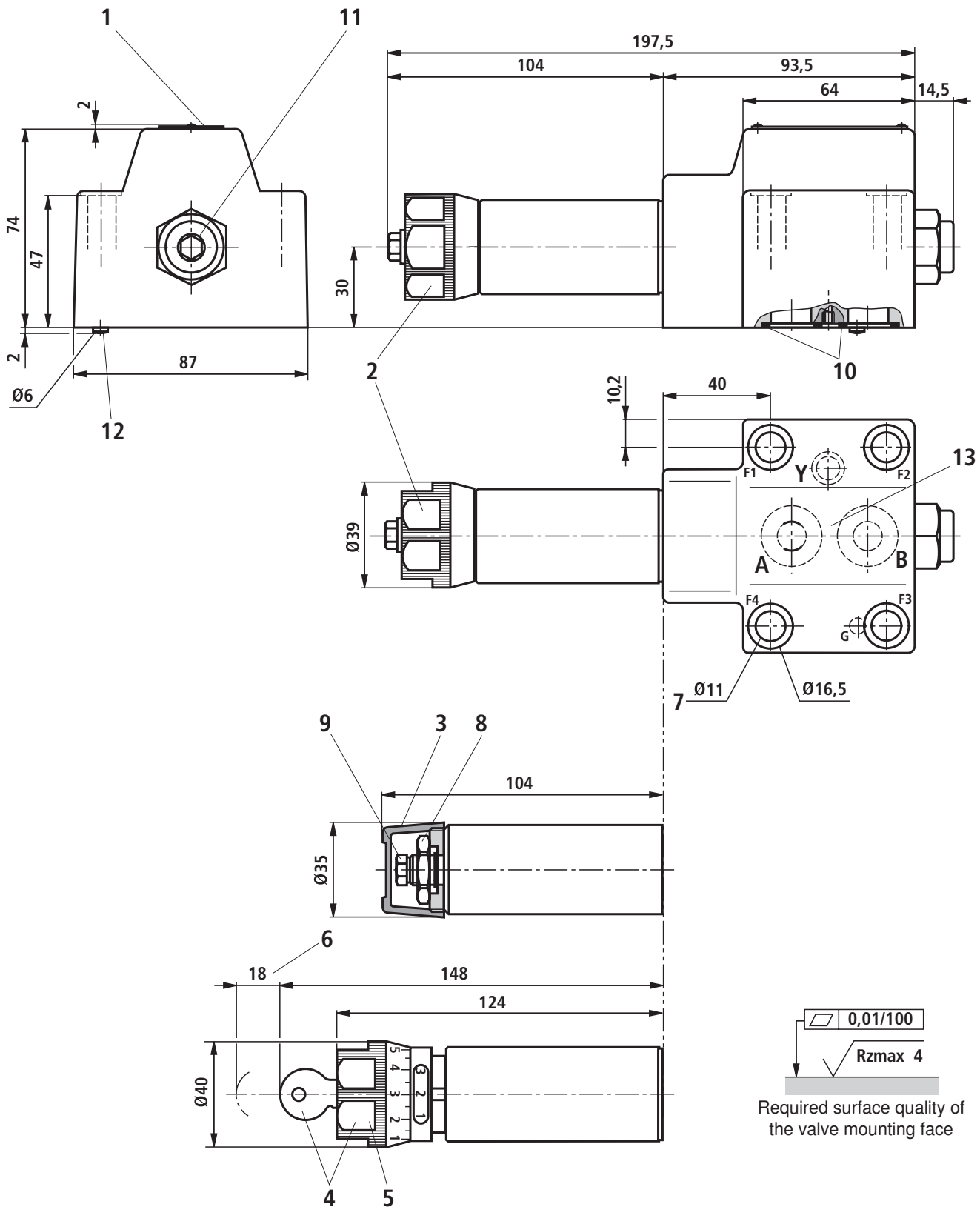

Item explanations, valve mounting screws and subplates see page 7.

Unit dimensions

- | | | |
|----|--|---|
| 1 | Name plate | Subplates according to data sheet 45062 (separate order) |
| 2 | Adjustment type "1" | G 460/01 (G3/8) |
| 3 | Adjustment type "2" | G 461/01 (G1/2) |
| 4 | Adjustment type "3" | |
| 5 | Adjustment type "7" | |
| 6 | Space required to remove the key | Valve mounting screws (separate order) |
| 7 | Valve mounting bores | 4 hexagon socket head cap screws metric |
| 8 | Lock nut SW24 | ISO 4762 - M10 x 60 - 10.9-fIZn-240h-L |
| 9 | Hexagon SW10 | with friction coefficient $\mu_{\text{total}} = 0.09$ to 0.14 , |
| 10 | Identical seal rings for ports A, B, P, T(Y) | Tightening torque $M_A = 60 \text{ Nm} \pm 10 \%$, |
| 11 | Pressure gauge connection G1/4; 12 deep.
Internal hexagon SW6 | Material no. R912000116 |
| 12 | Locating pin | |
| 13 | Porting pattern according to DIN 24340 Form D and
ISO 5781-06-07-0-00 | |